

A Brighter Solution

AMP DISPLAY INC.

SPECIFICATIONS

CUSTOMER	
CUSTOMER PART NO.	
AMP PART NO.	UP-C162CFILY
APPROVED BY	
DATE	

Approved For Specifications

Approved For Specifications & Sample

AMP DISPLAY INC

9856 SIXTH STREET RANCHO CUCAMONGA CA 91730

TEL: 909-980-13410 FAX: 909-980-1419

WWW.AMPDISPLAY.COM

APPROVED BY	CHECKED BY	ORGANIZED BY

Date : 2001/12/11

REVISION HISTORY

Revision Content	Ver	Date
Primary release	A	2005-12-29
Modify test parameter: P21	B	2008-6-5
Add coding rule: P24	B	2008-6-5
IC update	C	2010-7-15

CONTENTS

ITEM	PAGE
Cover	1
Ver Record	2
Content	3
General Specification	4
Lcd Module Drawing	5
Absolute Maximum Rating	6
Electrical Characteristic	7
Interface Pin Assignment	8
Electro-Optical characteristics	9-12
Block Diagram	13
Timing Characteristics	14-17
Display Commands	18
Character Map	19
Lcd Product Quality Standard & Reliability Test	20-21
Precautions	22
Package Information	23
Code System	24

GENERAL SPECIFICATION

Outline Size(mm)	80.0(L) × 36.0(W) × 14.5(T)MAX
Lcd Type	FSTN, WHITE/BLACK, Transflective / Negative
Display type	16(characters) × 2(line)
View Area(mm)	64.5 × 13.8
Display Area(mm)	57.7 × 11.8
Dots size(mm)	0.65 × 0.55
Dots pitch(mm)	0.70 × 0.60
Character Size(mm)	5.55 × 2.95
Character Pitch(mm)	6.25 × 3.65
Controller & driver	SPLC780D-01
View Direction	6 O'Clock
Interface mode	---
VDD&VOP(Type)	5.0 V & 5.0 V
Backlight(Type)	YELLOW-GREEN
Operation Temp.(°C)	0 to +50°C
Storage Temp.(°C)	-10 to +60°C

LCD MODULE DRAWING

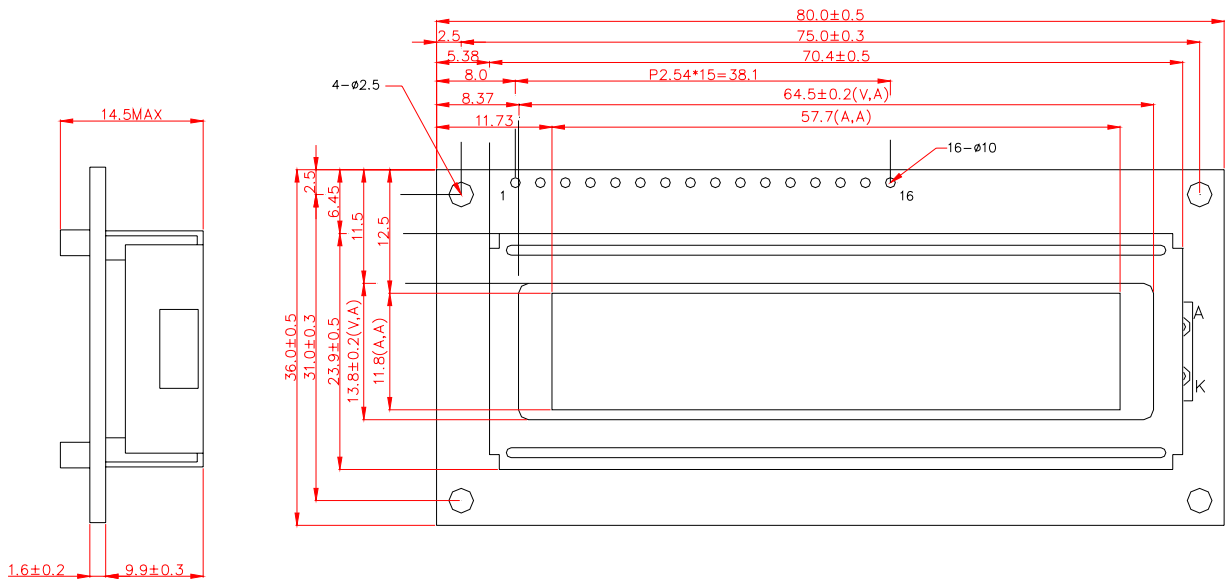

INTERFACE

PIN NO.	1	2	3	4	5	6	7	8	9	10
SYMBOL	VSS	VDD	V0	RS	R/W	E	DB0	DB1	DB2	DB3
PIN NO.	11	12	13	14	15	16	--	--	--	--
SYMBOL	DB4	DB5	DB6	DB7	A	K	--	--	--	--

ABSOLUTE MAXIMUM RATING

ELECTRICAL ABSOLUTE MAXIMUM RATINGS

ITEM	SYMBOL	MIN	MAX	UNIT	COMMENT
POWER SUPPLY FOR LOGIC	VDD-VSS	0	5.5	V	
POWER SUPPLY FOR LCD DRIVE	VDD-VO	0	5.3	V	
INPUT VOLTAGE	VI	VSS	VDD	V	
POWER SUPPLY FOR LED	VDD-VSS	3.9	4.3	V	

ENVIRONMENTAL ABSOLUTE MAXIMUM RATINGS

ITEM	OPERATING		STORAGE		COMMENT
	MIN	MAX	MIN	MAX	
AMBIENT TEMPERATURE(°C)	0	50	-10	+60	
HUMIDITY	NOTE(1)		NOTE(1)		WITHOUT CONDENSATION
VIBRATION (M/S^2)	/	/			SEE "ITEMS OF RELIABILITY"
TEMPERATURE CYCLING TEST	/	/			SEE "ITEMS OF RELIABILITY"
CORROSIVE GAS	NOT ACCEPTABLE		NOT ACCEPTABLE		

NOTE(1): $T_a \leq 40 \text{ }^\circ\text{C}$: 90% RH MAX

$T_a > 40 \text{ }^\circ\text{C}$: ABSOLUTE HUMIDITY MUST BE LOWER THAN THE HUMIDITY OF 90% RH AT 40°C.

ELECTRICAL CHARACTERISTICS(V_{SS}=0V)

Item	Symbol	Condition	Min.	Typ	Max.	Unit	note
Power Supply for Logic	V _{DD} -V _{SS}	T _a =-20~+70°C	4.5	5.0	5.5	Volt	
Input Voltage	V _{IL}	V _{DD} =5V±5%	V _{SS}		0.6	Volt	
	V _{IH}		2.2	-	V _{DD}	Volt	
Output Voltage	V _{OL}	V _{DD} =5V±5%	-	-	0.4	Volt	
	V _{OH}		2.4	-	-	Volt	
LCD drive Voltage(recommended Voltage)	V _{DD} -V _O				-	Volt	-
		T _a =25°C	-	5.0	-		
					-		
Power Supply Current for LCM	I _{DD}	V _{DD} =5.0V T _a =25°C	-	-	-	mA	-
	I _{LED}	V _{LED} = 4.1 V	-	-	-		

-

INTERFACE PIN ASSIGNMENT

Pin No.	Pin Out	Description
1	VSS	GND
2	VDD	Logic supply voltage (5.0V)
3	VO	Power supply for LCD
4	RS	Data/Instruction RS=high : Indicates that data of DB0~DB7 is display data. RS=low : Indicates that data of DB0~DB7 is instruction
5	R/W	Read/Write R/W=high : Data of DB0~DB7 can be read by CPU. R/W=low : Data of DB0~DB7 can be written into LCD driver IC..
6	E	Enable When write(R/W=low) : Data of DB0~DB7 is latched at the fall of E When read(R/W=high) : Data is read while E is at high level.
7	DB0	Data Bus line.
8	DB1	
9	DB2	
10	DB3	
11	DB4	
12	DB5	
13	DB6	
14	DB7	
15	A	LED+(INPUT DC+5V)
16	K	LED-

ELECTRO-OPTICAL CHARACTERISTICS

Item	Symbol	Condition	Min.	Typ	Max.	Unit	note
Viewing angle range	$\Theta_2 - \Theta_1$	$T_a = 25^\circ\text{C}$	20	-	-	Deg	K=1.4 A,B
	Φ		-	-	-		
Rise Time	T_r	$T_a = 25^\circ\text{C}$	-	250	400	mS	$\Phi = 10$ $\Theta = 0$ C
		$T_a = 0^\circ\text{C}$	-	-	-		
Fall Time	T_f	$T_a = 25^\circ\text{C}$	-	350	400	mS	$\Phi = 10$ $\Theta = 0$ C
		$T_a = 0^\circ\text{C}$	-	-	-		
Contrast	Cr	$T_a = 25^\circ\text{C}$	-	7	-	-	$\Phi = 10$ $\Theta = 0$ D

A. Definition of viewing angle (Θ & Φ)

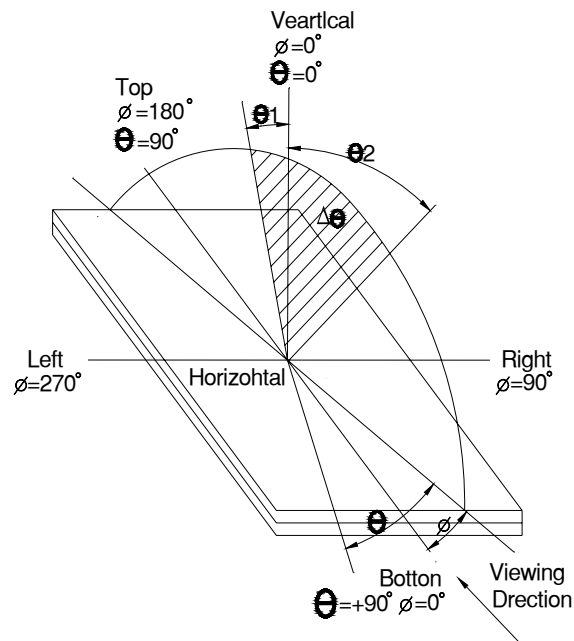

B. Definition of viewing angle (θ_1 & θ_2)

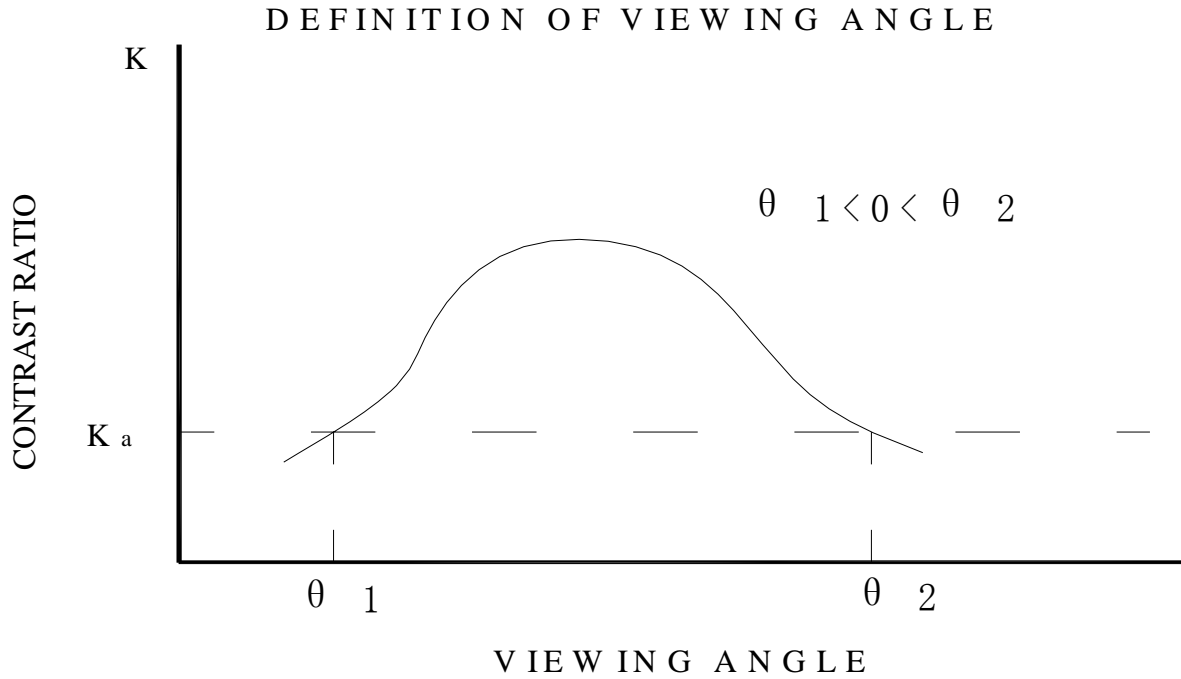

C. Definition of Response Time (T_r , T_f)

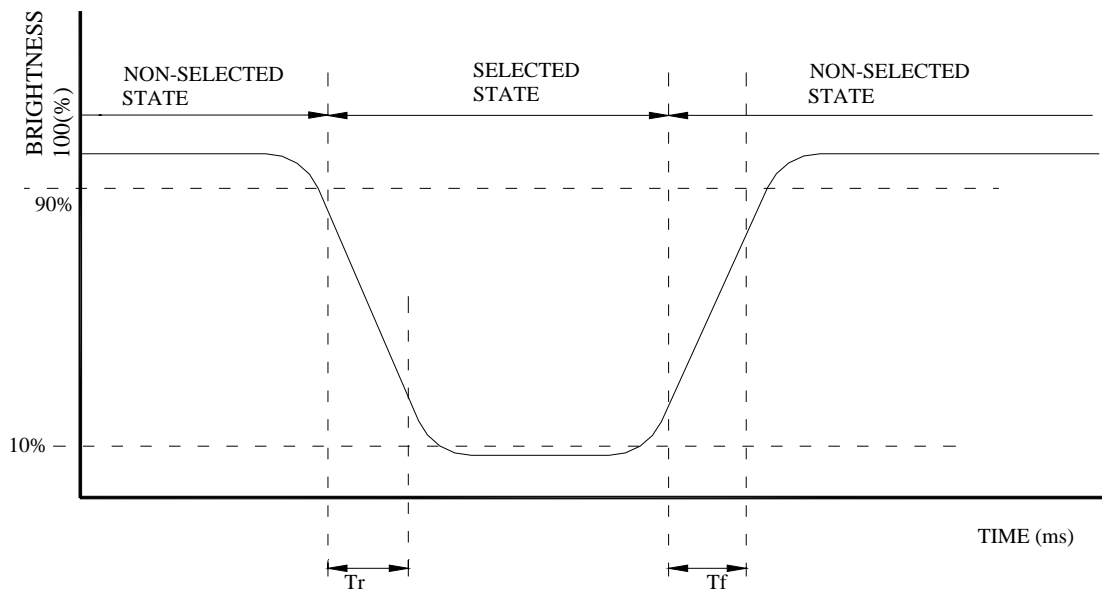

D. Definition of contrast ratio Cr

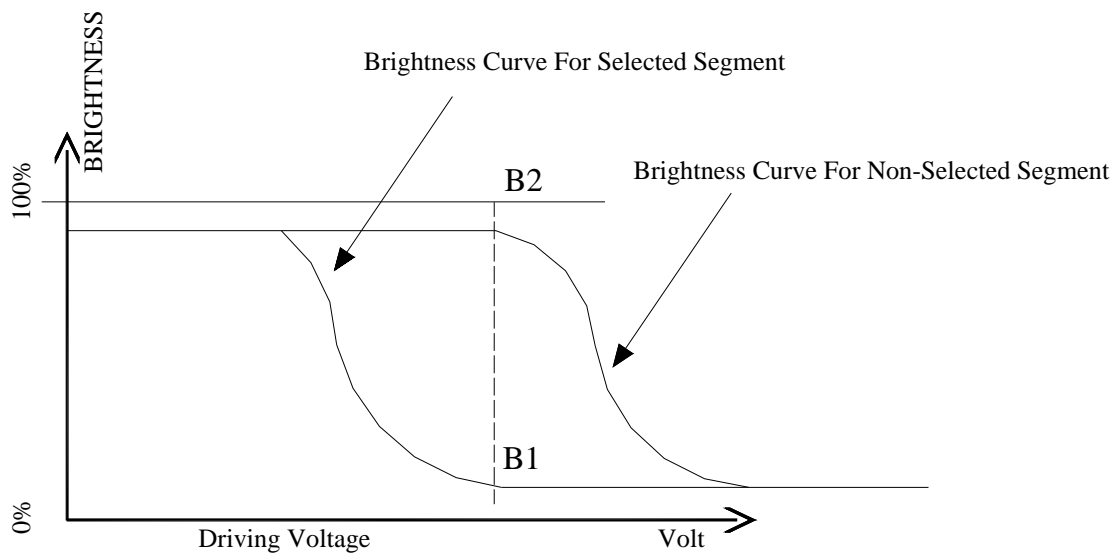

$$Cr = \frac{\text{Brightness of Non-selected Segment}(B2)}{\text{Brightness of selected Segment}(B1)}$$

Description of Measuring Equipment

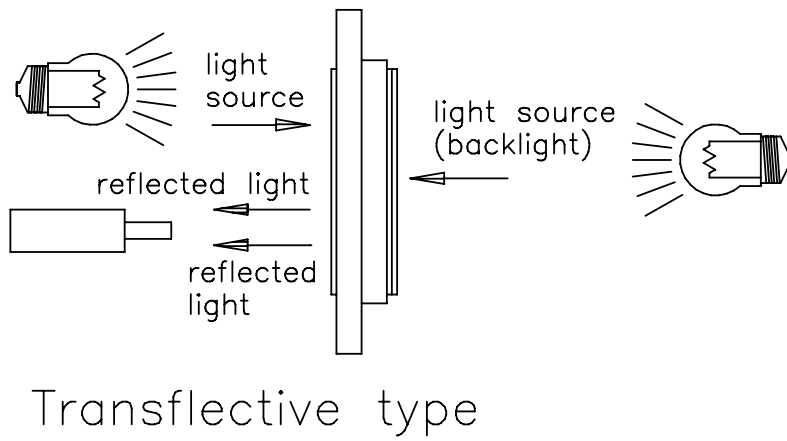
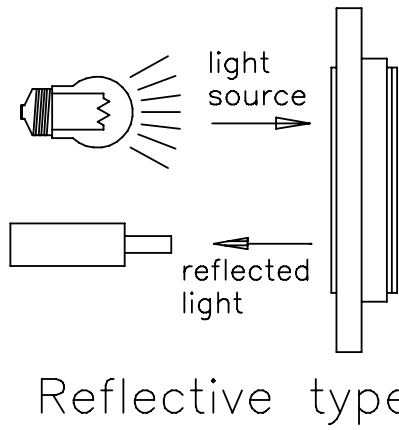

BLOCK DIAGRAM

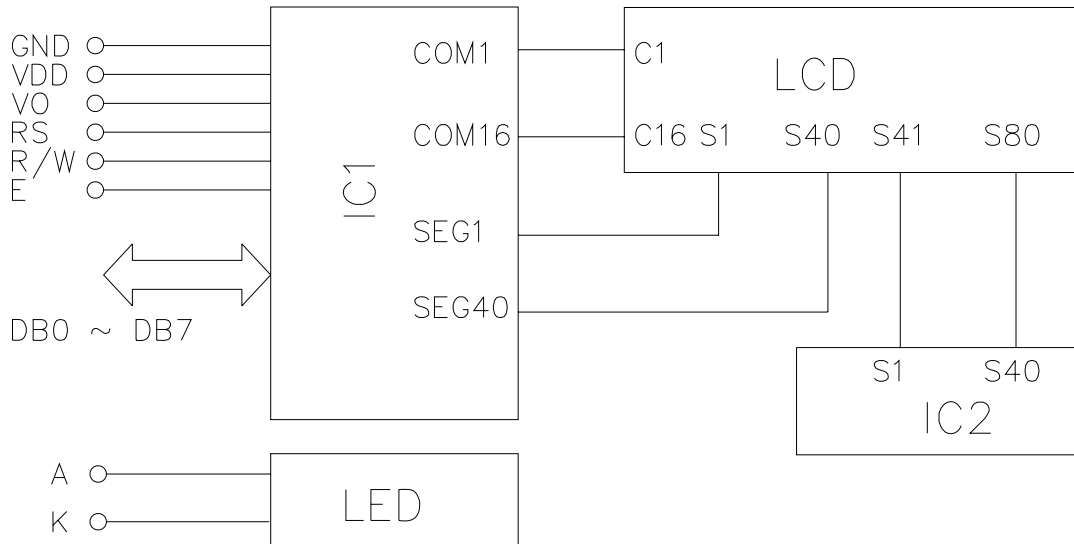

POWER SUPPLY

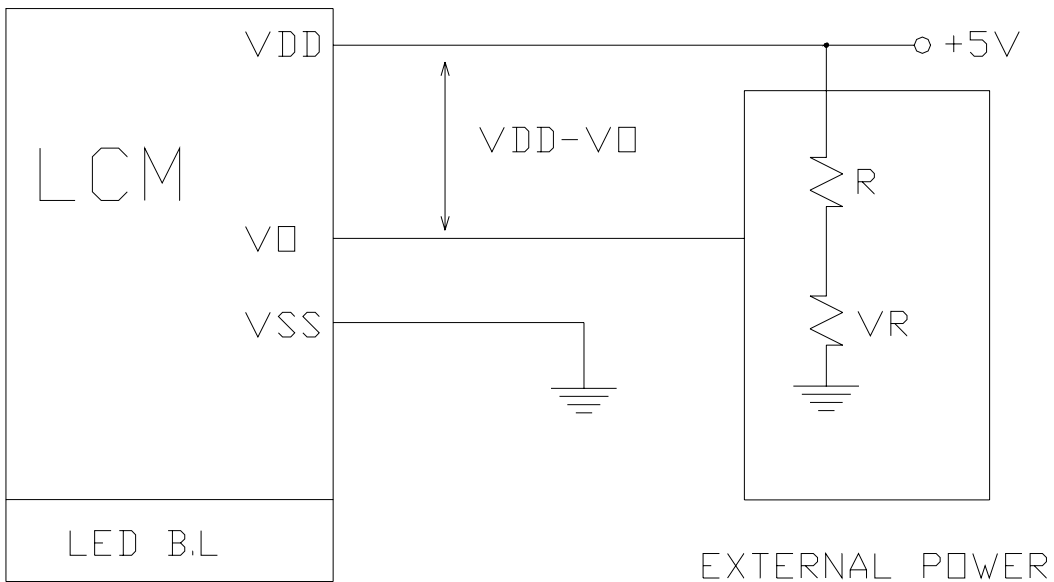

VDD-VO: LCD DRIVING VOLTAGE

VR: 10K ~ 20K

IF $V_{OP(LCD)} > 5.0V$, THE EXTERNAL POWER MUST BE USED

ELECTRICAL CHARACTERISTICS

DC Characteristics

Table 10. DC Characteristics (VDD=4.5V ~ 5.5V, Ta= -30 ~ +85 °C)

Characteristic	Symbol	Condition	Min	Typ	Max	Unit
Operating Voltage	VDD	-	4.5	-	5.5	V
Supply Current	IDD	Internal oscillation or external clock (VDD=5.0V, fosc=270 kHz)	-	0.35	0.6	mA
Input Voltage(1) (except OSC1)	VIH1	-	2.2	-	VDD	V
	VIL1	-	-0.3	-	0.6	
Input Voltage(2) (OSC1)	VIH2	-	VDD-1.0	-	VDD	V
	VIL2	-	-0.2	-	1.0	
Output Voltage(1) (DB0 ~ DB7)	VOH1	IOH = -0.205 mA	2.4	-	-	V
	VOL1	IOL = 1.2 mA	-	-	0.4	
Output Voltage(2) (except DB0 ~ DB7)	VOH2	IO = -40 μA	0.9VDD	-	-	V
	VOL2	IO = 40 μA	-	-	0.1VDD	
Voltage Drop	Vdcom	IO = ± 0.1 mA	-	-	1	V
	Vdseg		-	-	1	
Input Leakage Current	ILKG	VIN = 0 V to VDD	-1	-	1	μA
Input Low Current	IIL	VIN = 0 V, VDD = 5.0V (PULL UP)	-50	-125	-250	
Internal Clock (external Rf)	fosc1	Rf = 91 K Ω ±2% (VDD = 5.0V)	190	270	350	kHz
External Clock	fosc	-	125	270	410	kHz
	Duty		45	50	55	%
	Tr, Tf		-	-	0.2	μs
LCD Driving Voltage	VLCD	VDD - V5 (1/5, 1/4 Bias)	3.0	-	13.0	V

Table 11. DC Characteristics (VDD = 2.7 V ~ 4.5 V, Ta = -30 ~ +85°C)

Characteristic	Symbol	Condition	Min	Typ	Max	Unit
Operating Voltage	VDD	-	2.7	-	4.5	V
Supply Current	IDD	Internal oscillation or external clock (VDD=3.0V, fosc=270 kHz)	-	0.15	0.3	mA
Input Voltage(1) (except OSC1)	VIH1	-	0.7VDD	-	VDD	V
	VIL1	-	-0.3	-	0.55	
Input Voltage(2) (OSC1)	VIH2	-	0.7VDD	-	VDD	V
	VIL2	-	-	-	0.2VDD	
Output Voltage(1) (DB0 ~ DB7)	VOH1	IOH = -0.1 mA	0.75VDD	-	-	V
	VOL1	IOL = 0.1 mA	-	-	0.2VDD	
Output Voltage(2) (except DB0 ~ DB7)	VOH2	IO = -40 μA	0.8VDD	-	-	V
	VOL2	IO = 40 μA	-	-	0.2VDD	
Voltage Drop	Vdcom	IO = ± 0.1 mA	-	-	1	V
	Vdseg		-	-	1	
Input Leakage Current	ILKG	VIN = 0 V to VDD	-1	-	1	μA
Input Low Current	IIL	VIN = 0 V, VDD = 3.0V (PULL UP)	-10	-50	-120	
Internal Clock (external Rf)	fosc1	Rf = 75 K Ω ±2% (VDD = 3.0V)	190	270	350	kHz
External Clock	fosc	-	125	270	410	kHz

	Duty		45	50	55	%
	Tr,Tf		-	-	0.2	μs
LCD Driving Voltage	VLCD	VDD – V5 (1/5,1/4 Bias)	3.0	-	13.0	V

NOTE: LCD Driving Voltage

Power	Duty	1/8,1/11 Duty	1/16 Duty
	Bias	1/4 Bias	1/5 Bias
	VDD	VDD	VDD
	V1	VDD-VLCD/4	VDD-VLCD/5
	V2	VDD-VLCD/2	VDD-2VLCD/5
	V3	VDD-VLCD/2	VDD-3VLCD/5
	V4	VDD-3VLCD/4	VDD-4VLCD/5
	V5	VDD-VLCD	VDD-VLCD

AC Characteristics

Table 12. AC Characteristics(VDD = 4.5 V ~ 5.5 V,Ta= -30 ~ +85°C)

Mode	Characteristics	Symbol	Min	Typ	Max	Unit
Write Mode (Refer to Fig-6)	E Cycle Time	Tc	500	-	-	ns
	E Rise / Fall Time	Tr,Tf	-	-	20	
	E Pulse Width (High,Low)	Tw	230	-	-	
	R/W and RS Setup Time	Tsu1	40	-	-	
	R/W and RS Hold Time	Th1	10	-	-	
	Data Setup Time	Tsu2	80	-	-	
	Data Hold Time	Th2	10	-	-	
Read Mode (Refer to Fig-7)	E Cycle Time	Tc	500	-	-	ns
	E Rise / Fall Time	Tr,Tf	-	-	20	
	E Pulse Width (High,Low)	Tw	230	-	-	
	R/W and RS Setup Time	Tsu	40	-	-	
	R/W and RS Hold Time	Th	10	-	-	
	Data Output Delay Time	Td	-	-	120	
	Data Hold Time	Tdh	5	-	-	

Table 13. AC Characteristics(VDD = 2.7 V ~ 4.5 V,Ta= -30 ~ +85°C)

Mode	Characteristics	Symbol	Min	Typ	Max	Unit
Write Mode (Refer to Fig-6)	E Cycle Time	Tc	1000	-	-	ns
	E Rise / Fall Time	Tr,Tf	-	-	25	
	E Pulse Width (High,Low)	Tw	450	-	-	
	R/W and RS Setup Time	Tsu1	60	-	-	
	R/W and RS Hold Time	Th1	20	-	-	
	Data Setup Time	Tsu2	195	-	-	
	Data Hold Time	Th2	10	-	-	
Read Mode (Refer to Fig-7)	E Cycle Time	Tc	1000	-	-	ns
	E Rise / Fall Time	Tr,Tf	-	-	25	

	E Pulse Width (High,Low)	T_w	450	-	-
	R/W and RS Setup Time	T_{su}	60	-	-
	R/W and RS Hold Time	T_h	20	-	-
	Data Output Delay Time	T_d	-	-	360
	Data Hold Time	T_{dh}	5	-	-

Table 14. AC Characteristics($V_{DD} = 2.7\text{ V} \sim 4.5\text{ V}, T_a = -30 \sim +85^\circ\text{C}$)

Mode	Characteristics	Symbol	Min	Typ	Max	Unit
Interface Mode With Extension Driver (Refer to Fig-8)	Clock Pulse Width (High,Low)	T_c	500	-	-	ns
	Clock Rise / Fall Time	T_r, T_f	-	-	20	
	Clock Setup Time	T_{su1}	500	-	-	
	Data Setup Time	T_{su2}	300	-	-	
	Data Hold Time	T_{dh}	300	-	-	
	M Delay Time	T_{DM}	-1000	-	1000	

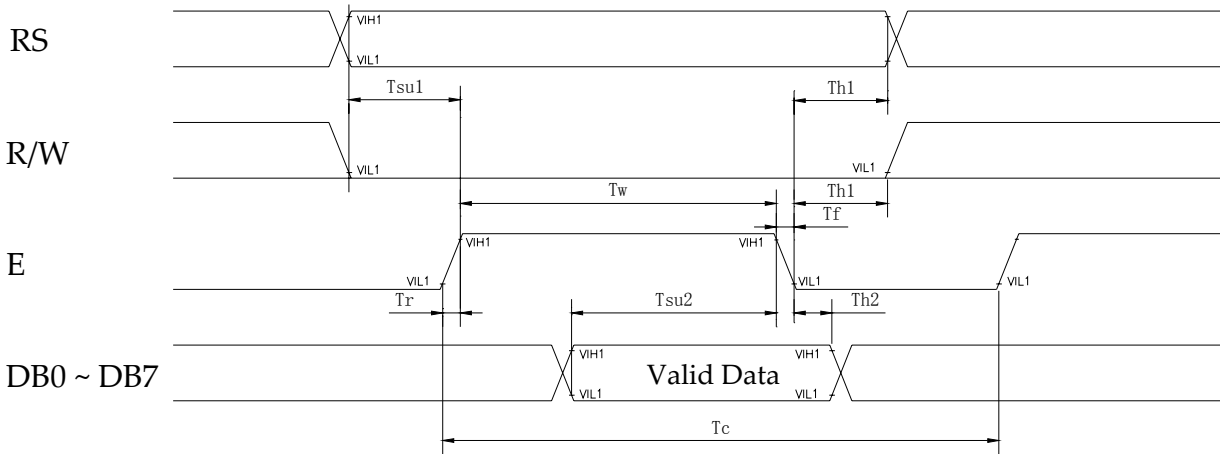

Figure 6. Write Mode Timing Diagram

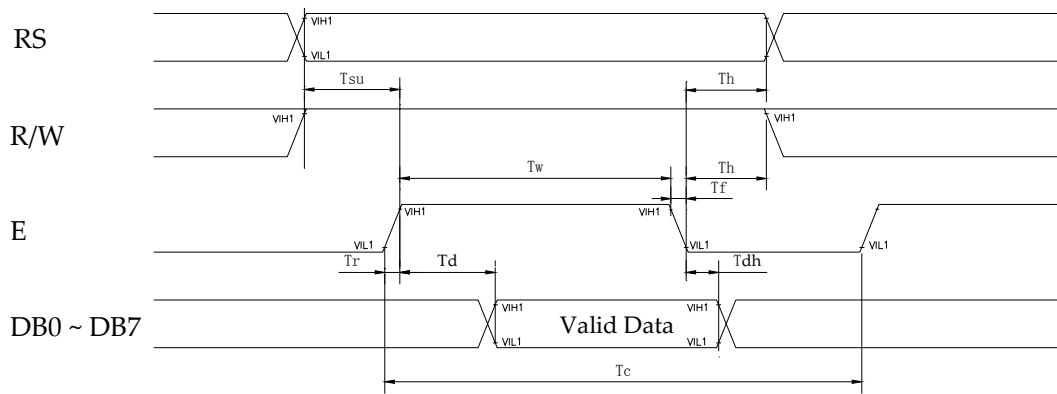

Figure 7. Read Mode Timing Diagram

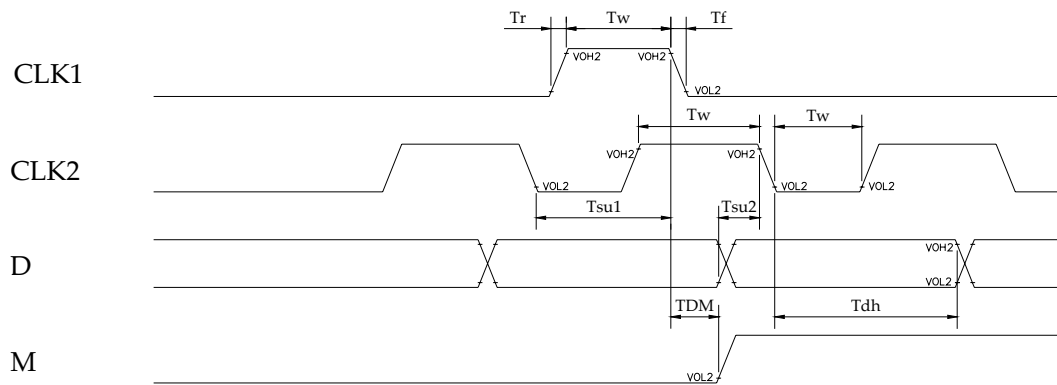

Figure 8. Interface Mode With Extension Driver Timing Diagram

DISPLAY COMMANDS

The display commands shown below control the internal state of the LCD driver ICs. Commands are sent from CPU to LCD module for the display control.

Table 7. Instruction Table

Instruction	Instruction Code										Description	Execution time (fosc= 270 kHz)	
	RS	R/W	DB7	DB6	DB5	DB4	DB3	DB2	DB1	DB0			
Clear Display	0	0	0	0	0	0	0	0	0	0	1	Write "20H" to DDRAM and set DDRAM address to "00H" from AC	1.53 ms
Return Home	0	0	0	0	0	0	0	0	0	1	-	Set DDRAM address to "00H" from AC and return cursor to its original position if shifted. The contents of DDRAM are not changed.	1.53 ms
Entry Mode Set	0	0	0	0	0	0	0	0	1	I/D	SH	Assign cursor moving direction and enable the shift of entire display.	39 μs
Display ON/OFF Control	0	0	0	0	0	0	0	1	D	C	B	Set display(D), cursor(C), and blinking of cursor(B) on/off control bit.	39 μs
Cursor or Display Shift	0	0	0	0	0	0	1	S/C	R/L	-	-	Set cursor moving and display shift control bit, and the direction, without changing of DDRAM data.	39 μs
Function Set	0	0	0	0	0	1	DL	N	F	-	-	Set interface data length (DL: 8-bit/4-bit), numbers of display line (N: 2-line/1-line) and, display font type (F:5×11dots/5×8 dots)	39 μs
Set CGRAM Address	0	0	0	1	AC5	AC4	AC3	AC2	AC1	AC0		Set CGRAM address in address counter.	39 μs
Set DDRAM Address	0	0	1	AC6	AC5	AC4	AC3	AC2	AC1	AC0		Set DDRAM address in address counter.	39 μs
Read Busy Flag and Address	0	1	BF	AC6	AC5	AC4	AC3	AC2	AC1	AC0		Whether during internal operation or not can be known by reading BF. The contents of address counter can also be read.	0 μs
Write Data to RAM	1	0	D7	D6	D5	D4	D3	D2	D1	D0		Write data into internal RAM (DDRAM/CGRAM).	43 μs
Read Data from RAM	1	1	D7	D6	D5	D4	D3	D2	D1	D0		Read data from internal RAM (DDRAM/CGRAM).	43 μs

* "-": don't care

NOTE: When an MPU program with checking the Busy Flag(DB7) is made, it must be necessary 1/2Fosc is necessary for executing the next instruction by the falling edge of the 'E' signal after the Busy Flag (DB7) goes to "Low".

Lower 4bit \ Upper 4bit	LLL	LLHL	LLHH	LHLL	LHLH	LHHL	LHHH	HLLL	HLLH	HLHL	HLHH	HHLL	HHLH	HHHL	HHHH
	LLL	CG RAM (1)													
LLH	(2)														
LLH	(3)														
LLH	(4)														
LHL	(5)														
LHL	(6)														
LHL	(7)														
LHH	(8)														
HLL	(1)														
HLL	(2)														
HLL	(3)														
HLL	(4)														
HLL	(5)														
HLL	(6)														
HLL	(7)														
HLL	(8)														

QUALITY LEVEL

Inspection conditions

ENVIRONMENTAL CONDITIONS

The environmental conditions for inspection shall be as follows: Room temperature: 22 ± 3 °C ; Humidity: $50 \pm 10\%$ RH

The external visual inspection

The inspection shall be performed by using a single 20W fluorescent lamp for illumination and the distance from LCD to eyes of the inspector should be 30cm or more.

Classification of defects

A major defect

A major defect refers to A defect which may substantially degrade usability for product applications.

Minor defect

A Minor defect refers to A defect which is not considered to substantially degrade product application or A defect which deviates from existing standards almost unrelated to the effective use of the product or its operation

Sampling procedures for each items acceptance level table

Defect type	Sampling procedures	AQL
Major defect	MIL-STD-105D Inspection level1 normal inspection Single sample inspection	1.0
Minor defect	MIL-STD-105D Inspection level1 normal inspection Single sample inspection	2.5

Life time

50,000Hrs(25°C in the room without ray of sun)

ITEMS OF RELIABILITY

ITEM	CONDITIONS	CRITERION
High temperature operation test	+50°C \ 120 hours	1. It judged at room temperature after 2 hours to be good as appearance and electrical test is normal after the experiment. 2. Current consumption should within the specification of Approval sheet Electro-optical characteristics
Low temperature operation test	0°C \ 120 hours	5-10pcs

High temperature/humidity storage test	+60°C,80%±10%RH \ 120 hours	
High temperature storage test	+60°C \ 120 hours	
Low temperature storage test	0°C \ 120 hours	
Temperature cycling test	<p style="text-align: center;">-10°C (30 min) ↓ ↑ 25°C (5 min) ↓ ↑ 60°C (30 min)</p> <p style="text-align: center;">CYCLES: 10</p>	
Vibration	Random Wave: 10 ~ 50 Hz Each Direction (x, y, z): 30MIN.	

11. Cosmetic criteria of LCD screen

DEFECT	JUDGEMENT CRITERION		
Spots	Size d (mm)	Acceptable quantity in active area	
	d ≤ 0.1	Disregard	
	0.1 < d ≤ 0.2	6	
	0.2 < d ≤ 0.3	2	
	d > 0.3	0	
	Note: d = (Length + Width)/2		
Polarizer Bubbles	Size d (mm)	Acceptable quantity in active area	
	d ≤ 0.3	Disregard	
	0.3 < d ≤ 1.0	3	
	1.0 < d ≤ 1.5	1	
	d > 1.5	0	
	Note: d = (Length + Width)/2		
Lines	Width W (mm) Length L (mm)	Acceptable quantity in active area	
	W ≤ 0.02	Disregard	
	0.02 < W ≤ 0.05	L ≤ 5.0	6
		L > 5.0	0
	0.05 < W ≤ 0.1	L ≤ 2.0	6
		L > 2.0	0
W > 0.1	See criteria for spots		
Testing conditions: 20W fluorescent lamp at 30 cm distance at normal viewing angle			

PRECAUTIONS

Static charge

Since this LCD module contains CMOS LSI that are sensitive to static charge, care must be taken when handling it.

Power on sequence

1. Input signals should not be applied to the LCD module before the logic system voltage has reached the specified voltage. If the above sequence is not kept, the LCD module might be permanently damaged.
2. When connecting the power supply, connect the LCD bias voltage after connecting the logic system voltage.
3. When disconnecting the power supply, disconnect the logic system voltage after the LCD bias voltage.
4. It is recommended to connect a serial resistor or fuse to the LCD bias power supply of the system as a current limiter. The value of the resistor depends on the kind of LCD used, but is typically 50~100 Ω

Operation

1. It is essential to drive the LCD within the specified voltage limits, since a higher driving voltage than allowed causes a shorter LCD lifetime. Under these circumstances, electrochemical reactions will result in undesirable deterioration of the LCD.
2. The response time of the LC fluid is considerably longer at low temperature than in the normal operating temperature range. On the other hand, the LCD will show a dark blue color at high temperatures. Those phenomena do not indicate a malfunction or defect of the LCD. Back at normal temperatures, the LCD will return to its original behavior.
3. If the display area is pressed hard during operation, some abnormal display patterns might appear. However, the display will resume normal operation after turning the module off and on.
4. Moisture on the terminals could cause an electrochemical reaction resulting in an open terminal connection. If the environmental temperature is higher than 50°C, it is required that the relative humidity is 50% or less.

Long-time storage

For long-term storage the following methods are highly recommended:

1. Store the product in a polyethylene bag with a sealed opening to prevent fresh air entering from the outside. Placing it with a desiccant is not necessary.
2. Store the product in a dark place, with the temperature in the range from -10°C to 60°C.
3. Keep the sensitive polarizer surface of the LCD panels clear of any contact. We recommend using the container that was used by Vsky to deliver the products.

Cleaning of product

To clean the product make sure to use absorbent cotton cloth or other soft material like chamois. Make sure to rub it gently and do not use chemicals when cleaning.

PACKAGE INFORMATION

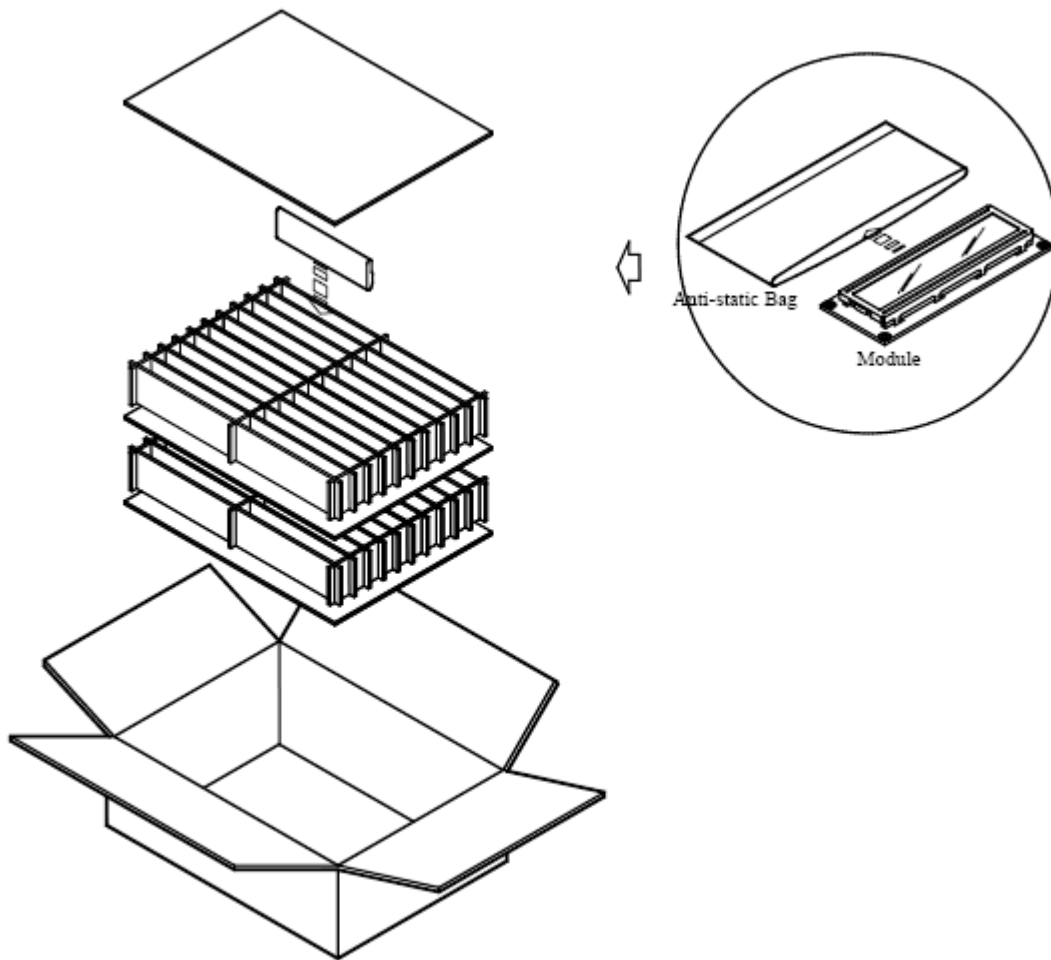

Code System :

UP—X XX XX X X X X X X— X
1 2 3 4 5 6 7 8 9 10

1: Module type: S-SEGMENT,
C-CHARACTER;
G-GRAPHIC;

2,3: Display type: LINE *ROW ;

4: Serial number: A~Z;

-
- 5: Lcd mode: G-GRAY/STN;
Y-YELLOW-GREEN/STN;
T-TN,HTN;
F-FSTN;
S-BLUE/STN;
- 6: Polarizer mode: A~D: REFLECTIVE;
I,J,F,K: TRANSFLECTIVE;
M,N,L,O: TRANSMISSIVE;
T,U,P,Q: NEGATIVE;
- 7: Backlight mode: L-LED BACKLIGHT;
E-EL BACKLIGHT;
C-CCFL;
- 8: Backlight color: Y-YELLOW GREEN;
B-BLUE;
W-WHITE;
A-AMBER;
E-ORANGE;
- 9: Temperature range: W-WIDE TEMP.
BLANK-NORMAL TEMP.
- 10: Structure: T-TAB/TCP;
G-COG;
H-HEAT SEAL;
BLANK-COB.