

AMP DISPLAY INC.

A Brighter Solution

SPECIFICATIONS

CUSTOMER	
CUSTOMER PART NO.	
AMP PART NO.	AG-12864D
APPROVED BY	
DATE	

Approved For Specifications

Approved For Specifications & Sample

AMP DISPLAY INC

9856 SIXTH STREET RANCHO CUCAMONGA CA 91730
TEL: 909-980-13410 FAX: 909-980-1419
WWW.AMPDISPLAY.COM

APPROVED BY	CHECKED BY	ORGANIZED BY

Date : 2007/2/7

RECORD OF REVISION

Revision Date	Page	Contents	Editor
1999/10/5	-	New Release	
2000/10/6	10	Add power on / off sequence	
	11	Modify sampling plan	
2000/10/27	3 ,6	Modify LED characteristic	
2001/12/12			
2002/6/12	6,9	Modify LED characteristic	Spencer
2007/2/7	6	Modify EL Back-light Characteristics	Edward

1 FEATURES

- (1) Display format : 128 × 64 dot-matrix ; 1/ 64 duty.
- (2) Construction : LCD, Bezel, Zebra and PCB.
- (3) Optional Edge LED or EL back-light.
- (4) Controller : T6963C.
- (5) 5V single power input. Built-in DC/DC converter for LCD driving.
- (6) Normal / Extended temperature type.

2 NUMBERING SYSTEM

AG-12864D _ _ _ _ - _
1 2 3 4 5

No	Code Value	Description	Remark
1	G	STN gray type LCD	LCD Type
	Y	STN yellow green type LCD	
	S	STN negative type LCD	
	F	FSTN type LCD	
2	A	Reflective type / 6:00 view	Polarizer / Viewing Angel
	B	Reflective type / 12:00 view	
	I	Transflective type / 6:00 view	
	J	Transflective type / 12:00 view	
	T	Negative type / 6:00 view	
	U	Negative type / 12:00 view	
3	None	Without backlight	Backlight type
	Q	5V Edge type LED	
	E	EL	
4	None	Without backlight	Backlight color
	Y	Yellow-green (LED)	
	B	Blue (EL)	
	W	White (EL, LED)	
5	None	Normal temperature type	LCM temperature type
	H	Extended temperature type	

2 MECHANICAL DATA

Parameter	Standard Value	Unit
Dot size	0.40 (W) × 0.56(H)	mm
Dot pitch	0.44(W) × 0.60(H)	mm
Viewing area	62.0(W) × 44.0(H)	mm
Module size	78.0(W) × 70.0(H) × 10.5 max (T)	mm
Module size (w/ LED back-light)	78.0(W) × 70.0(H) × 13.0 max (T)	mm

3 ABSOLUTE MAXIMUM RATINGS

Parameter		Symbol	Min	Max	Unit
Logic Circuit Supply Voltage		VDD-VSS	-0.3	7.0	V
LCD Driving Voltage		VDD-VO	-0.3	16.0	V
Input Voltage		VI	-0.3	VDD+0.3	V
Normal temp. type	Operating Temp.	TOP	0	50	°C
	Storage Temp.	TSTG	-20	70	°C
Extended temp. type	Operating Temp.	TOP	-20	70	°C
	Storage Temp.	TSTG	-30	80	°C

4 ELECTRO-OPTICAL CHARACTERISTICS

Parameter	Symbol	Condition	Min	Typ	Max	Unit	Note
----- Electronic Characteristics -----							
Logic Circuit Supply Voltage	VDD-VSS	--	4.5	5.0	5.5	V	
LCD Driving Voltage	VDD-VO	-20 °C	8.3	8.8	9.3	V	0 ~ 50 °C for Normal Temp. type -20 ~ 70 °C for Extended Temp. type
		0 °C	8.2	8.7	9.2		
		25 °C	8.0	8.5	9.0		
		50 °C	7.8	8.3	8.8		
		70 °C	7.7	8.2	8.7		
Input Voltage	VIH	--	0.7 VDD	--	VDD	V	
	VIL	--	VSS	--	0.3 VDD	V	
Logic Supply Current	IDD	VDD = 5V	--	3	6	mA	
----- Optical Characteristics -----							
Contrast	CR	STN type	--	5	--		Note 1
		FSTN type		8			
Rise Time	tr	25°C	--	140	--	ms	Note 2
Fall Time	tf	25°C	--	240	--	ms	
Viewing Angle Range	θ f	25°C & CR≥2	--	40	--	Deg.	Note 3
	θ b		--	35	--		
	θ l		--	35	--		
	θ r		--	35	--		
Frame Frequency	fF	25°C	--	64	--	Hz	
----- Yellow-green LED Back-light Characteristics -----							
Forward Voltage	VF	--	--	4.05	4.3	V	Supply Voltage between A&K
Forward Current	IF	VF=4.05V	--	100	--	mA	
LCM Luminous intensity		VF=4.05V	--	7	--	cd/m ²	

* LED Dice number = 2x10=20

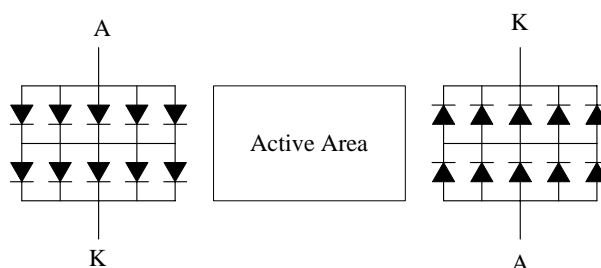

----- White Edge LED Back-light Characteristics -----							
Forward Voltage	VF	--	--	3.2	3.5	V	Supply Voltage between A&K
Forward Current	IF	VF=3.2V	--	90	--	mA	
LCM Luminous intensity		VF=3.2V	--	7.2	--	cd/m ²	

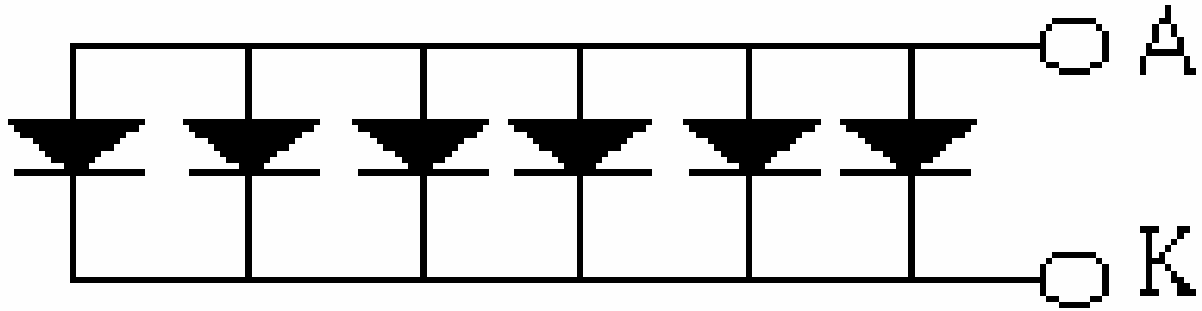

Parameter	Min	Typ	Max	Unit	Note
----- EL Back-light Characteristics -----					
Driving Voltage	--	110	--	Vrms	
Frequency	--	400	--	Hz	
LCM Luminous intensity	--	5	--	cd/m ²	

(NOTE 1) Contrast ratio :

$$CR = (\text{Brightness in OFF state}) / (\text{Brightness in ON state})$$

(NOTE 2) Response time :

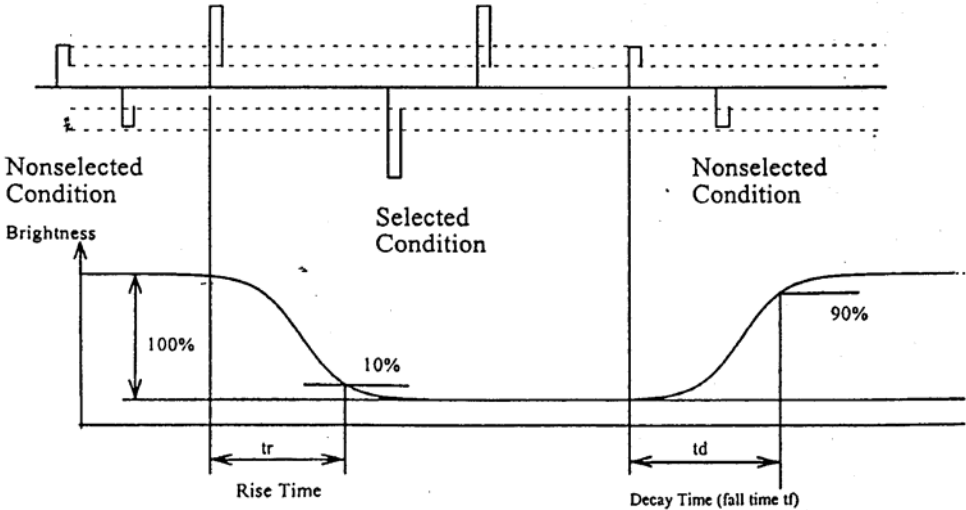

(NOTE 3) Viewing angle

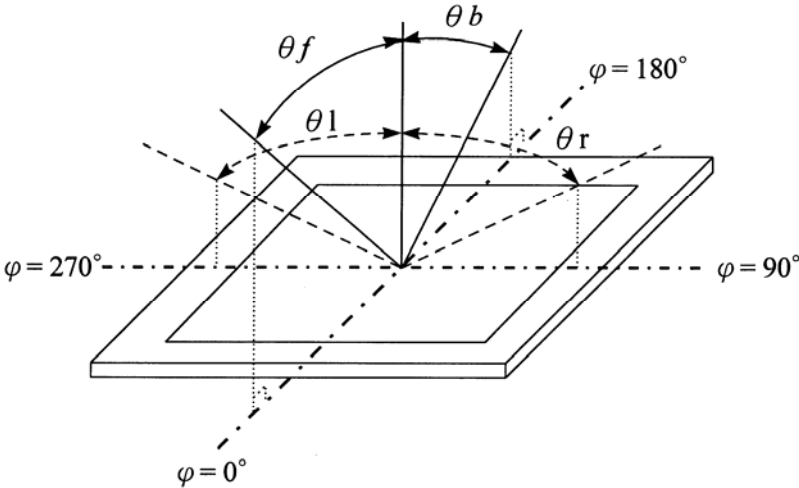

5 BLOCK DIAGRAM & POWER SUPPLY

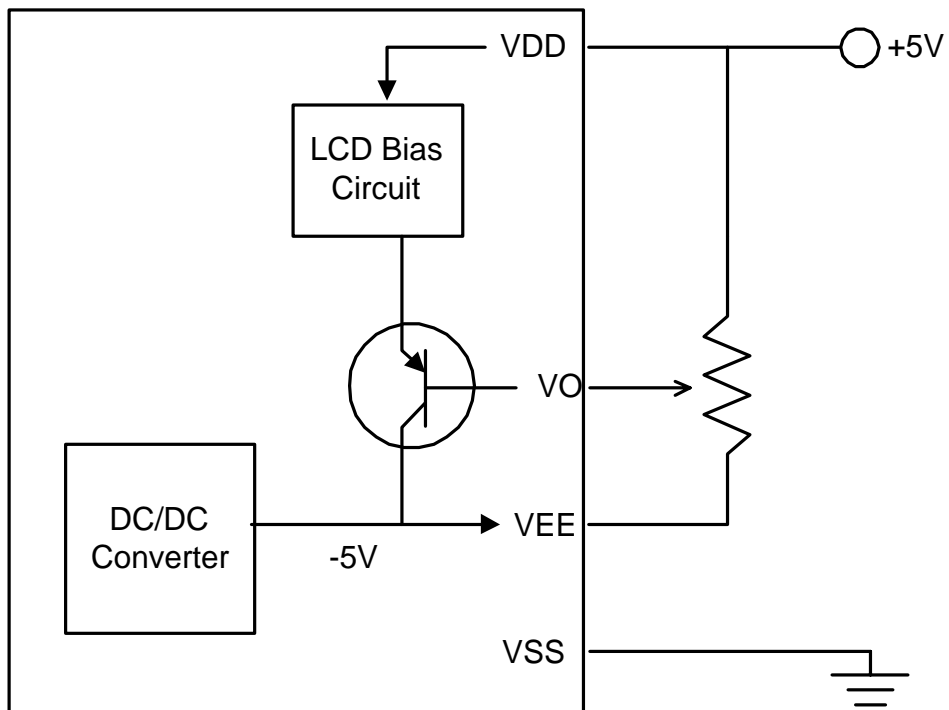
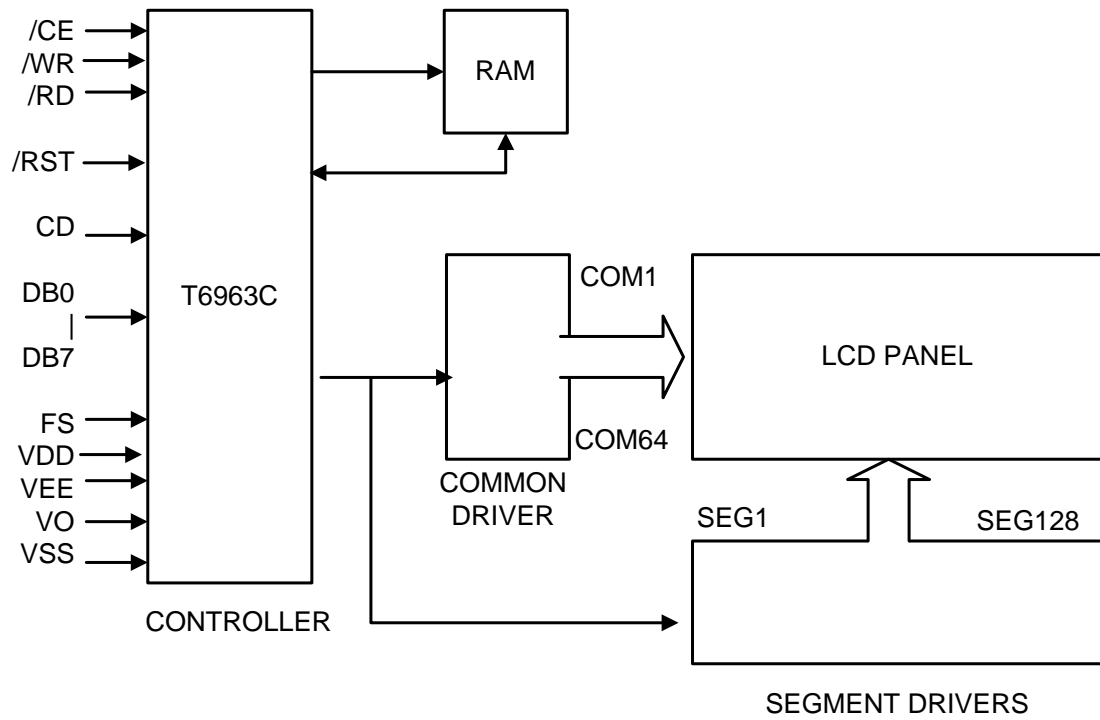

Using LED Back-light

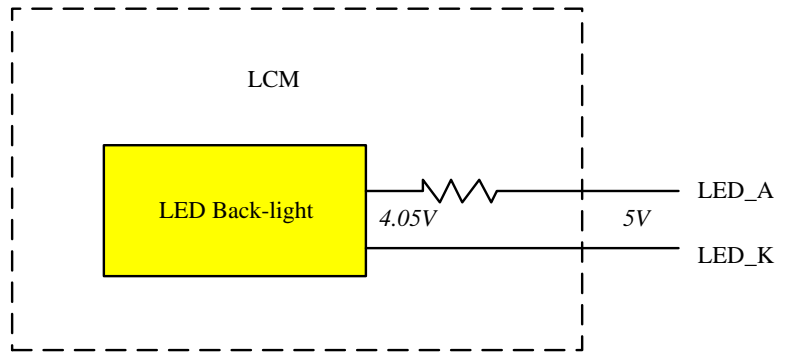

Using EL Back-light

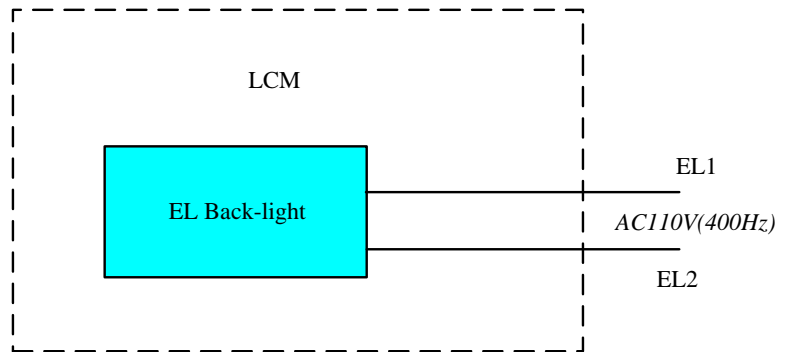

Using White LED Back-light

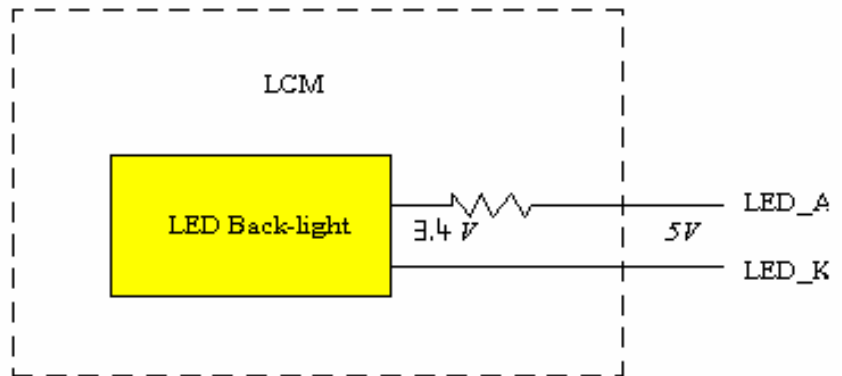

6 PIN CONNECTIONS

No.	Symbol	Function
1	VEE	Negative Power Supply Output (-5V)
2	VSS	Ground (0V)
3	VDD	Supply Voltage for Logic (+5V)
4	VO	Constant adjustment
5	/WR	Data Write
6	/RD	Data Read
7	/CE	Chip Enable
8	C/D	Code/Data
9	/RST	Reset
10-17	DB0-DB7	Data Bus Line
18	FS	Font Select H: 6x8 (default) L : 8x8
19	LEDA	LED Supply Voltage + (5V)
20	LEDK	LED Supply Voltage - (5V)

7 TIMING CHARACTERISTICS

Bus Timing

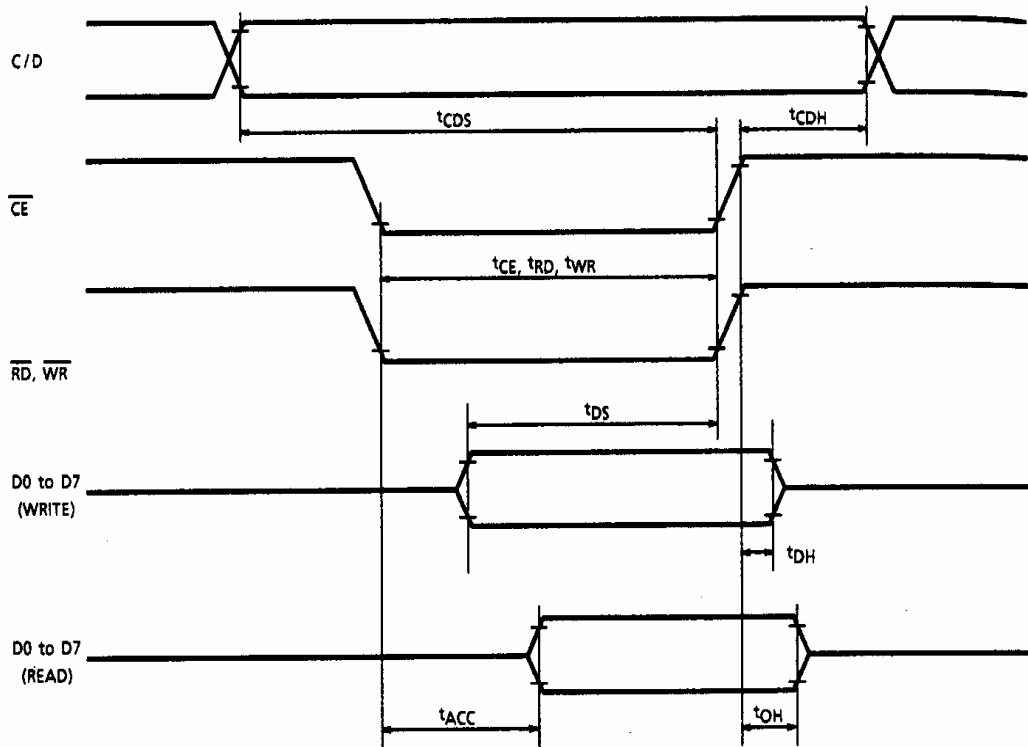

TEST CONDITIONS (Unless otherwise noted, $V_{DD} = 5.0V \pm 10\%$, $V_{SS} = 0V$, $T_a = -20$ to $75^\circ C$)

ITEM	SYMBOL	TEST CONDITIONS	MIN	MAX	UNIT
C/D Set-up Time	t_{CDS}	—	100	—	ns
C/D Hold Time	t_{CDH}	—	10	—	ns
\overline{CE} , \overline{RD} , \overline{WR} Pulse Width	$t_{CE, t_{RD}, t_{WR}}$	—	80	—	ns
Data Set-up Time	t_{DS}	—	80	—	ns
Data Hold Time	t_{DH}	—	40	—	ns
Access Time	t_{ACC}	—	—	150	ns
Output Hold Time	t_{OH}	—	10	50	ns

7.1 Power ON/OFF Sequence

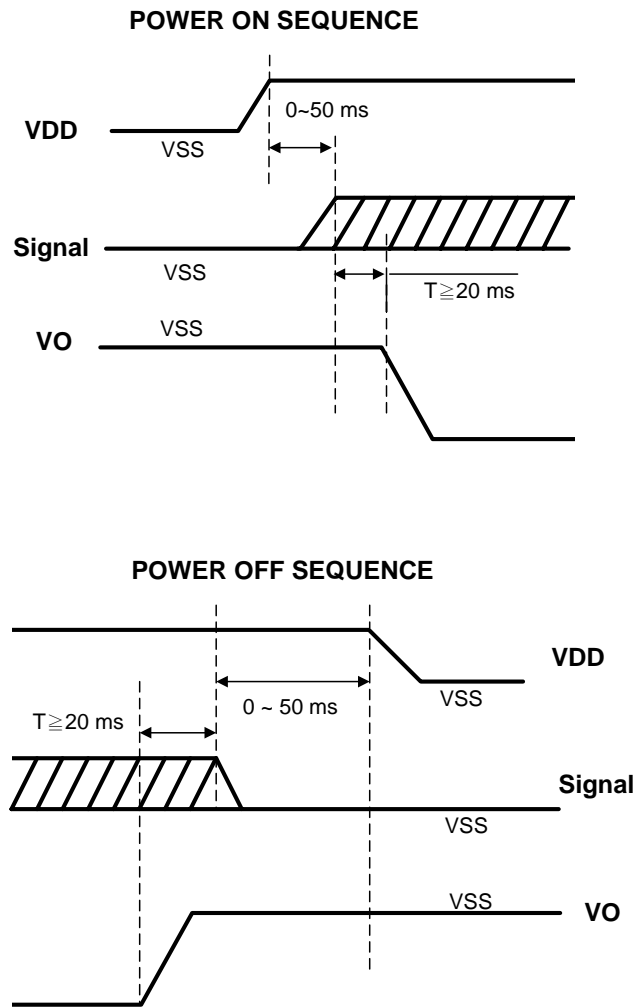

8 QUALITY AND RELIABILITY

8.1 TEST CONDITIONS

Tests should be conducted under the following conditions :

Ambient temperature : $25 \pm 5^{\circ}\text{C}$

Humidity : $60 \pm 25\% \text{ RH}$.

8.2 SAMPLING PLAN

Sampling method shall be in accordance with MIL-STD-105E , level II, normal single sampling plan .

8.3 ACCEPTABLE QUALITY LEVEL

A major defect is defined as one that could cause failure to or materially reduce the usability of the unit for its intended purpose. A minor defect is one that does not materially reduce the usability of the unit for its intended purpose or is an infringement from established standards and has no significant bearing on its effective use or operation.

8.4 APPEARANCE

An appearance test should be conducted by human sight at approximately 30 cm distance from the LCD module under fluorescent light. The inspection area of LCD panel shall be within the range of following limits.

8.5 INSPECTION QUALITY CRITERIA

Item	Description of defects			Class of Defects	Acceptable level (%)
Function	Short circuit or Pattern cut			Major	0.65
Dimension	Deviation from drawings			Major	1.5
Black spots	Ave . dia . D	area A	area B	Minor	2.5
	$D \leq 0.2$	Disregard			
	$0.2 < D \leq 0.3$	3	4		
	$0.3 < D \leq 0.4$	2	3		
	$0.4 < D$	0	1		
Black lines	Width W, Length L	A	B	Minor	2.5
	$W \leq 0.03$	disregard			
	$0.03 < W \leq 0.05$	3	4		
	$0.05 < W \leq 0.07, L \leq 3.0$	1	1		
	See line criteria				
Bubbles in polarizer	Average diameter D $0.2 < D < 0.5$ mm for N = 4 , D > 0.5 for N = 1			Minor	2.5
Color uniformity	Rainbow color or newton ring.			Minor	2.5
Glass Scratches	Obvious visible damage.			Minor	2.5
Contrast ratio	See note 1			Minor	2.5
Response time	See note 2			Minor	2.5
Viewing angle	See note 3			Minor	2.5

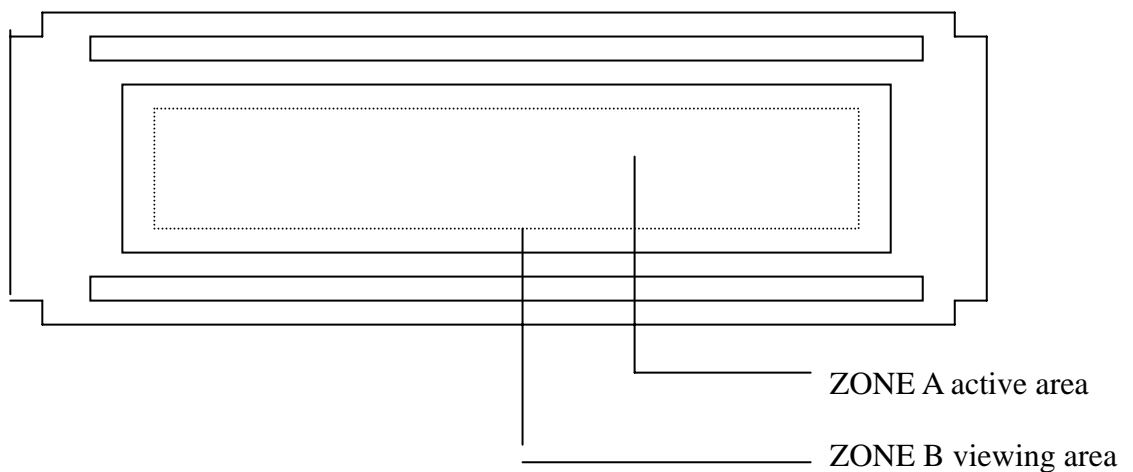

8.6 RELIABILITY

Test Item	Test Conditions		Note
	Normal Temp. type	Extended Temp. type	
High Temperature Operation	50±3°C , t=96 hrs	70±3°C , t=96 hrs	
Low Temperature Operation	0±3°C , t=96 hrs	-20±3°C , t=96 hrs	
High Temperature Storage	70±3°C , t=96 hrs	80±3°C , t=96 hrs	1,2
Low Temperature Storage	-20±3°C , t=96 hrs	-30±3°C , t=96 hrs	1,2
Temperature Cycle	-20°C ~ 25°C ~ 70°C 30 m in. 5 min. 30 min. (1 cycle) Total 5 cycle	-30°C ~ 25°C ~ 80°C 30 min. 5 min. 30 min. (1 cycle) Total 5 cycle	1,2
Humidity Test	40 °C, Humidity 90%, 96 hrs		1,2
Vibration Test (Packing)	Sweep frequency : 10 ~ 55 ~ 10 Hz/1min Amplitude : 0.75mm Test direction : X.Y.Z/3 axis Duration : 30min/each axis		2

Note 1 : Condensation of water is not permitted on the module.

Note 2 : The module should be inspected after 1 hour storage in normal conditions
(15-35°C , 45-65%RH).

Definitions of life end point :

- Current drain should be smaller than the specific value.
- Function of the module should be maintained.
- Appearance and display quality should not have degraded noticeably.
- Contrast ratio should be greater than 50% of the initial value.

9 HANDLING PRECAUTIONS

- (1) A LCD module is a fragile item and should not be subjected to strong mechanical shocks.
- (2) Avoid applying pressure to the module surface. This will distort the glass and cause a change in color.
- (3) Under no circumstances should the position of the bezel tabs or their shape be modified.
- (4) Do not modify the display PCB in either shape or positioning of components.
- (5) Do not modify or move location of the zebra or heat seal connectors.
- (6) The device should only be soldered to during interfacing. Modification to other areas of the board should not be carried out.
- (7) In the event of LCD breakage and resultant leakage of fluid do not inhale, ingest or make contact with the skin. If contact is made rinse immediately.
- (8) When cleaning the module use a soft damp cloth with a mild solvent, such as Isopropyl or Ethyl alcohol. The use of water, ketone or aromatic is not permitted.
- (9) Prior to initial power up input signals should not be applied.
- (10) Protect the module against static electricity and observe appropriate anti-static precautions.

10 OUTLINE DIMENSION

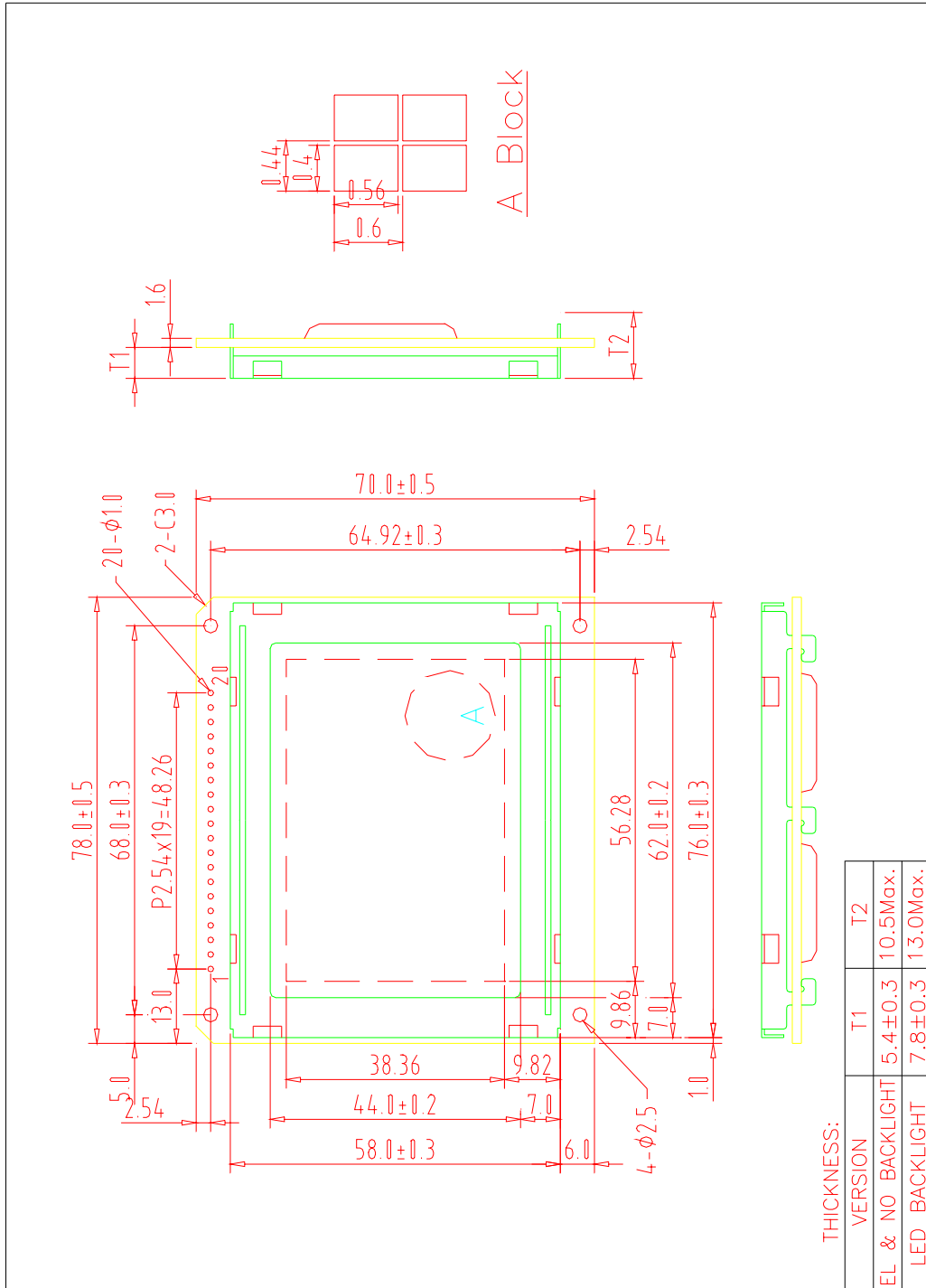

12864D